

6KProducts

Bringing reliability to high pressure hydraulic systems

Connect and Cut System Firewood Processor Component List Hydraulic Schematic

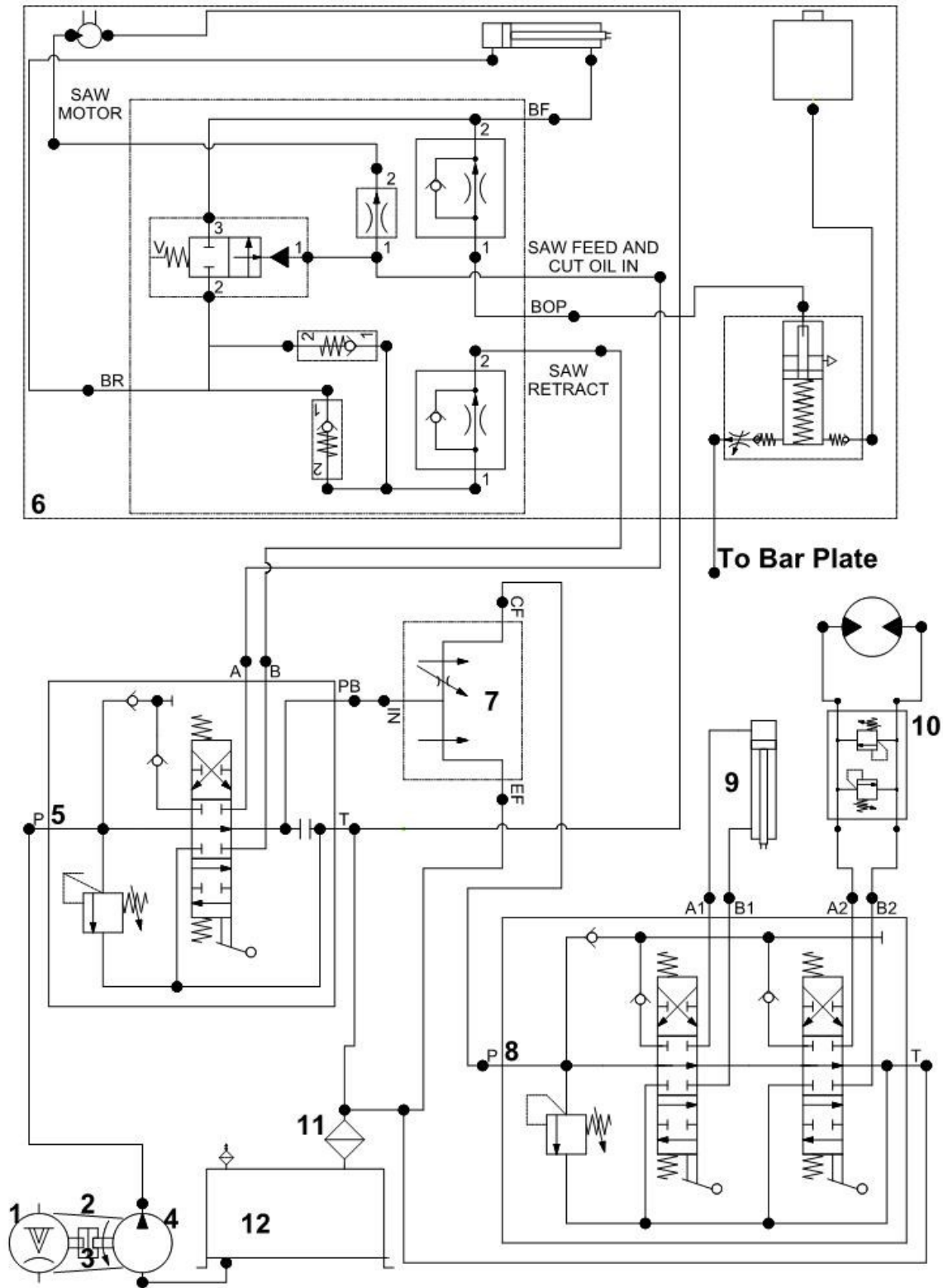

Item No.	Description	Item No.	Description
1	Engine	7	Priority Flow Divider
2	Hydraulic Pump Mounting Bracket	8	Two Spool Directional Valve
3	Shaft Coupler Assembly	9	Log Clamping Cylinder
4	Gear Type Hydraulic Pump	10	Log Infeed Motor and Cross Port Relief
5	Single Spool Hydraulic Valve With Power Beyond	11	Return Filter
6	Connect and Cut Saw System	12	Hydraulic Oil Tank